

# Kent Hidden Curved Slot Drain



**KENT HIDDEN CURVED SLOT DRAIN (KHSC 125/130/30-10)****Specify:**

Kent Hidden Curved Slot Drain KHSC 125/130/30-10; Grade 316 SS; Hidden; 130mm overall height, 125mm width; 10mm slot; Radius as per drawing

**Description:**

Kent Hidden Curved Slot Drain (KHSC-125/130/30-10) is a highly effective yet discreet drainage solution for public realm landscapes. The Slot is cut back from 100mm to 30mm which leaves the end result as an open slot with no visible stainless steel. The Kent Slot Drain System is made up of five different products; Kent Slot Channel, Recessed Access Cover, Outlet Point, Access Point and Connectors.

Kent Hidden Curved Slot Drain is a variation of the Kent Hidden Slot Channel and is manufactured to the clients needs. This channel can be made to almost any radius necessary whether it is a long slow radius or a short sharp radius. As standard the channel has similar dimensions to the straight lengths of Slot Drain.

**Features:**

- B125 Loading as Standard- C250 & D400 versions also available
- Curve radius manufactured to spec
- Available in either Grade 316 or grade 304 Stainless steel.
- 30mm Throat height, 10mm internal slot
- 125mm or 175mm widths available
- Visible, hidden or curved options available

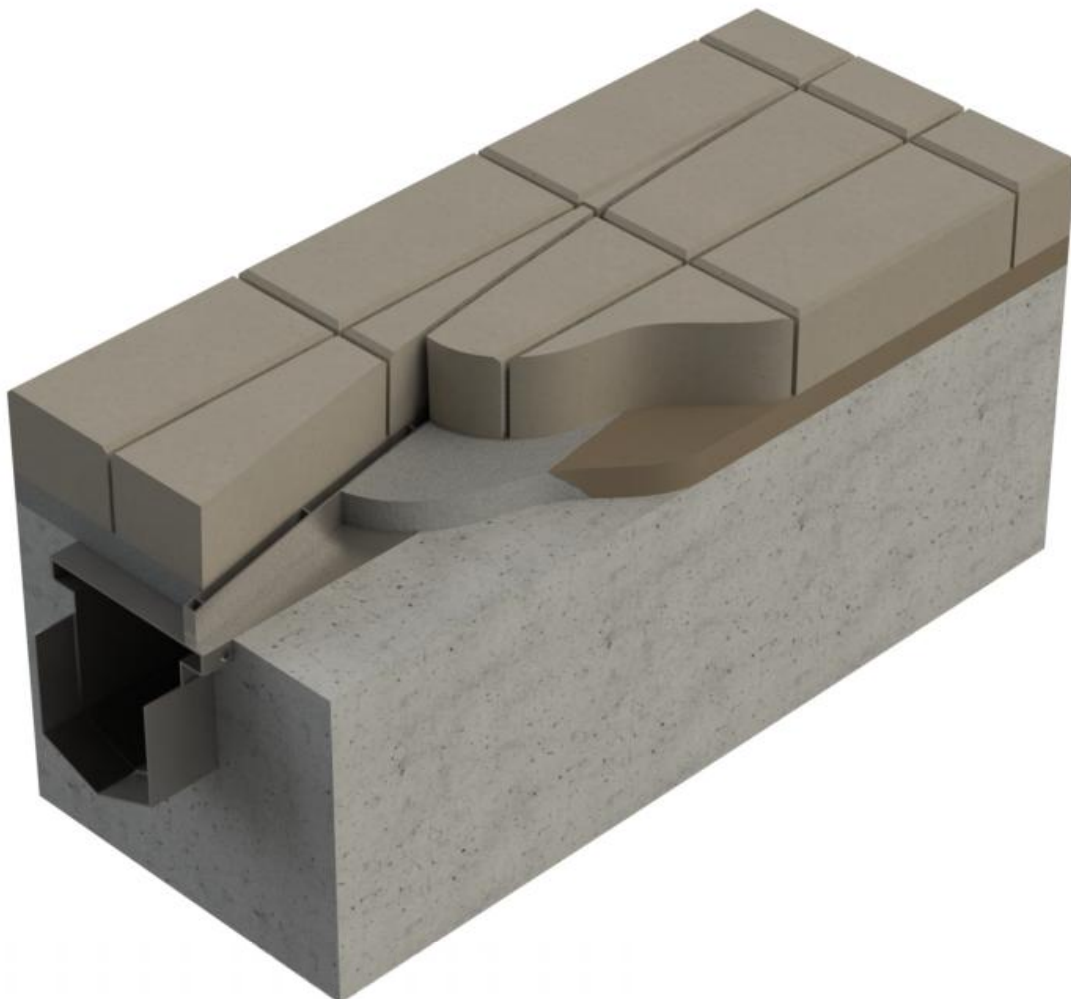

## KENT HIDDEN CURVED SLOT DRAIN (KHSC 125/130/30-10)

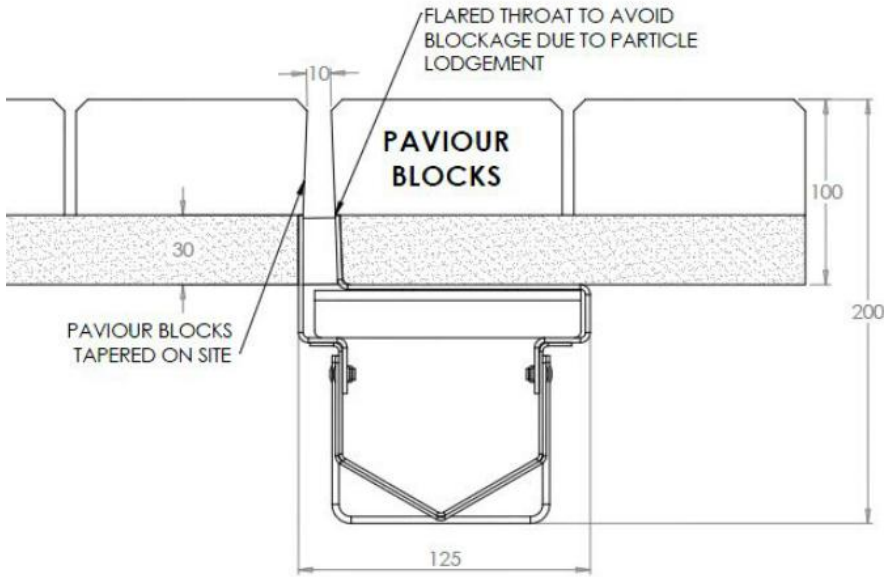

Product Code	Height	Width	Flow Rate
Kent Hidden Curved Slot Channel KHSC125/130/30-10	130	125	2.3 L/s
Kent Hidden Curved Slot Channel KHSC125/180/30-10	180	125	5.0 L/s
Kent Hidden Curved Slot Channel KHSC125/230/30-10	230	125	8.0 L/s
Kent Hidden Curved Slot Channel KHSC175/180/30-10	180	175	8.0 L/s
Kent Hidden Curved Slot Channel KHSC175/230/30-10	230	175	13.0 L/s
Kent Hidden Curved Slot Channel KHSC175/280/30-10	280	175	18.0 L/s

### Slot Drain System Elements:

These products when combined make the Kent Slot Drain System.

We recommend the installation of an Recessed access box and either an outlet or access point every 12 meters to ensure cleaning of the drain is possible.

Connectors are used to join channels and access points and end caps are used to cut off the flow of water at the end of a run.

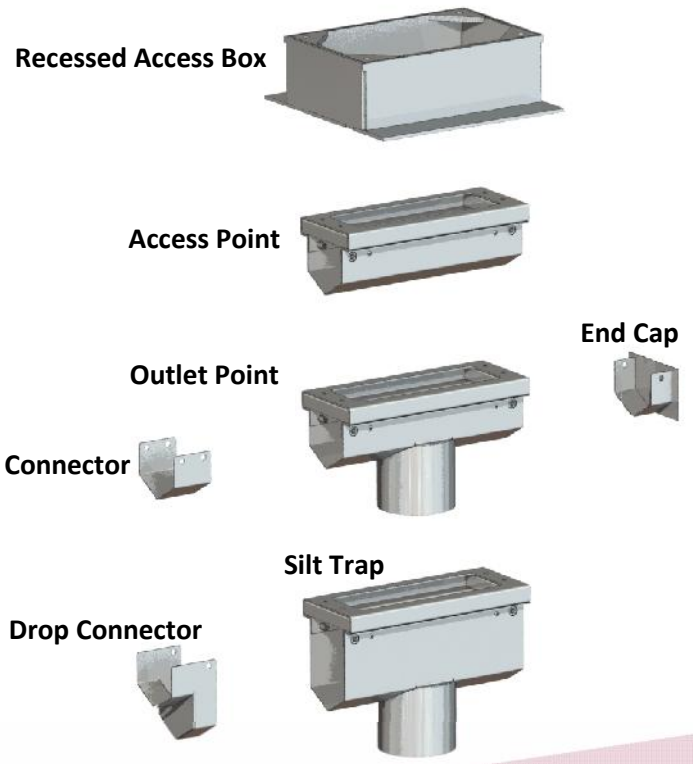



**KENT HIDDEN CURVED SLOT DRAIN (KHCS 125/130/30-10)**

**Specify**

**Customise your size:**  
To suit your projects needs  
or go with our standard  
1000mm length x 125mm  
width x 200mm dept.

**Choose your steel:**  
Grade 304 Stainless steel  
Grade 316 Stainless steel

**Specify:**  
Kent Hidden Curved Slot Drain KHCS 125/130/30-10; Grade 316 SS; Hidden; 130mm overall height, 125mm width; 10mm slot; FACTA B; Radius as per drawing

**Loading Options:**  
FACTAA  
FACTA AA  
FACTA AAA  
FACTA B  
FACTA C  
FACTA D

**Choose you throat**  
Hidden  
Visible

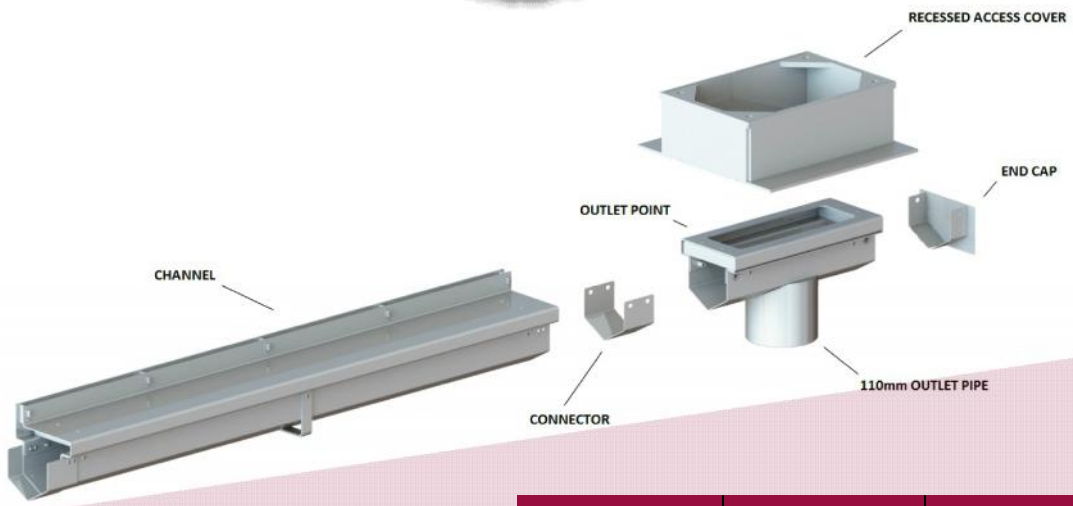

Options
Curved
Visible
Hidden
Grade 304 Stainless Steel
Grade 316 Stainless Steel

FACTA Class	EN124 Class	Slow Moving Wheel Loads	Kent Safety Test
A	A15	0.6T	0.8T
AA	N/A	1.5T	3.1T
AAA	N/A	2.5T	5.2T
B	B125	5T	10.1T
C	C250	6.5T	13.2T
D	D400	11T	22T

## Installed Projects

**Canada Water, London (UK)**  
Kent Curved Slot Drain system



**Cubitt Park, London (UK)**  
Kent Visible Slot Drain installed for use in a water fountain



**Bloomberg, London (UK)**  
Kent Hidden Curved Slot Drain Installed in Bloomberg, London



**Leadenhall, London**  
Kent Hidden Slot Drain Installed in Leadenhall, London

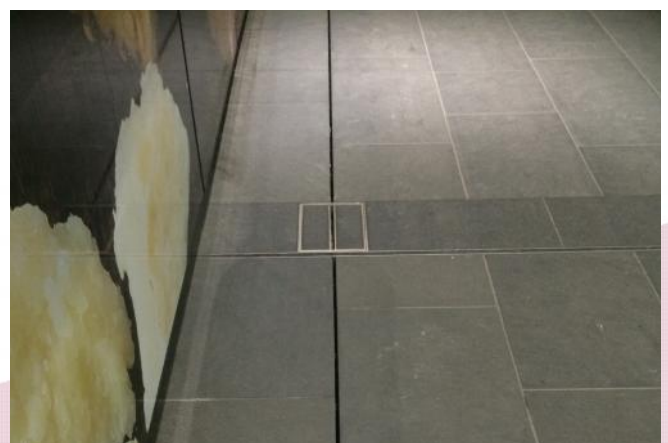

**KENT HIDDEN CURVED SLOT DRAIN (KHCS 125/130/30-10)****Maintenance of Stainless Steel**

Clean the stainless steel components using warm water with a mild detergent with a non-abrasive cloth or sponge. Heavier stains may require the use of a nylon-scouring pad or a stainless steel cleaner.

To remove paint or graffiti use a cloth and Alkaline or solvent paint strippers according to type of paint. In the case of a bead blasted finish, where abrasive cleaning is required, always use a random circular rubbing action with a cloth.

In the case of brushed finishes the surface consists of uniform fine 'scratches' running in one direction so where abrasive cleaning is required always use a straight back and forward rubbing action in the direction of the grain using soap and warm water.

Rust spots or 'tea stains' can occur on the surface of the material, these are normally caused by contamination from ordinary mild steel, particularly in areas where construction work has been undertaken. Such stains can be removed using Rust Remover 410.

In cases where the surface is severely stained because of severe environmental conditions or scratched due to misuse, it may still be possible to restore the original finish using chemicals such as Oxalic Acid solution. There are many stainless steel polishes available to enhance the surface finish.

We recommend Mister Stainless Ltd. as a provider for stainless steel cleaning products.



**Testimonials**

**PARSONS**  
 Parsons International Limited  
 P. O. Box 2091, Doha, Qatar • Tel: (+974) 4408-8444 • Fax: (974) 4437-7434 • www.parsons.com

Kent Stainless  
 Ankovan, Westford  
 Ireland

5 January 2012

Attention : Mr. Shane Curtis & Michael Harley  
 Project : Lussail Construction Package 1 - CPI  
 Subject : CPI, Kent Stainless, Lussail City, Qatar

Dear Shane & Michael,

I am writing to express my thanks for the works delivered by Kent Stainless to the Lussail Project in Doha. Your willingness to work with the client, designers and contractors to finalise the specifier detailing, produce the shop drawings and samples has been second to none and has added significant value to the project.

The in-house engineering completed by Kent Stainless and the knowledge and advice given to finalise the design was outstanding. All the products delivered to date have been fully compliant and of the highest quality.

Finally, your frequent presence on site and customer focus has enabled this technically difficult package of works to be finalised in the shortest possible time.

We hope to see you again on future projects.

Yours Sincerely

Patrick McComack  
 Parsons CPI

*“ The In-house engineering completed by Kent Stainless and the Knowledge and advice given to finalise the design was outstanding ”*

**- Parsons**

**SKANSKA**

Skanska Construction UK Ltd T/A  
 Skanska Infrastructure Services  
 Ltd  
 Maple Grove House  
 Dunham Way  
 Maple Grove  
 Rixton, Lancashire  
 Warrington, WIG3 9SS

Phone: +44 (0)1923 776888  
 Fax: +44 (0)1923 423593  
 Web: www.skanska.co.uk  
 Reg. in: England  
 Reg. No: 5314328  
 Registered Office: Maple Grove House  
 Dunham Way, Maple Grove, Warrington,  
 Cheshire, Warrington, WIG3 9SS

For the attention of: Michael Hurley

Kent Stainless  
 Ardavan  
 Westford  
 Ireland

Our ref: MW/002/20312  
 Your ref: 29 March 2010

Dear Michael,

Re: Letchworth Garden City, Manholes, Grittes, Drainage & Tree Pit Frames

With reference to Letchworth Garden City, we were delighted to work on such a prestigious award winning scheme. The choice of subcontractor and suppliers was crucial to us delivering such a high standard & Kent Stainless were instrumental in this.

As with all our projects during the last 5 years Kent delivered promptly and with the right quality - thanks for your help & keep up the good work.

The client and the main contractor both were delighted with the quality of the work supplied by Kent Stainless. You showed great flexibility and your quality was right first time again.

Yours faithfully,  
 for and on behalf of  
 Skanska Infrastructure Services

Matt Wincott

*“ The client and the main contractor both were delighted with the quality of the work supplied by Kent Stainless ”*

**- Skanska**

**DIRECTOR OF SERVICES  
 CORPORATE AFFAIRS & ROADS**  
 ADEIM

15<sup>th</sup> January 2010

Mr. Stephen Roche,  
 Kent Stainless,  
 Ankovan,  
 Westford,  
 Ireland.

RE: Wexford Main Street Regeneration

Dear Stephen,

Thanks for your help with the designs of manholes and gully covers for Wexford Main Street. We invested heavily in the new paving works and to have so beautiful stone work with red cast covers would have been a real shame. The solutions you provided with recessed covers in stainless steel with laser engraving blended in perfectly with the look and feel we wanted to portray for the street.

Because of the engineering know-how you provided and flexibility in design, we will certainly return to Kents for further work. We were designed to find an Irish manufacturer could provide all solutions, and even better a Wexford based engineering firm.

Yours faithfully,

  
 Adrian Doyle,  
 Director of Services,  
 Corporate Affairs & Roads

e-mail: adrian.doyle@wexfordcc.ie  
 tel: 053 9176400

100 Years of Community Service  
 Cuid 100 bli ag teilim arís le Wexford

*“ Because of the engineering know-how you provided and flexibility in design, we will certainly return to Kents for further work ”*

**- Wexford County Council**



**Kent Stainless Ltd**

Ardcavan, Wexford, Ireland

**TEL NO:** +353 53 9143216  
**UK FREEPHONE:** 0800 376 8377  
**FAX:** +353 53 9141802  
**WEB:** [www.kentstainless.com](http://www.kentstainless.com)  
**EMAIL:** [info@kentstainless.com](mailto:info@kentstainless.com)

